

PLAN VIEW

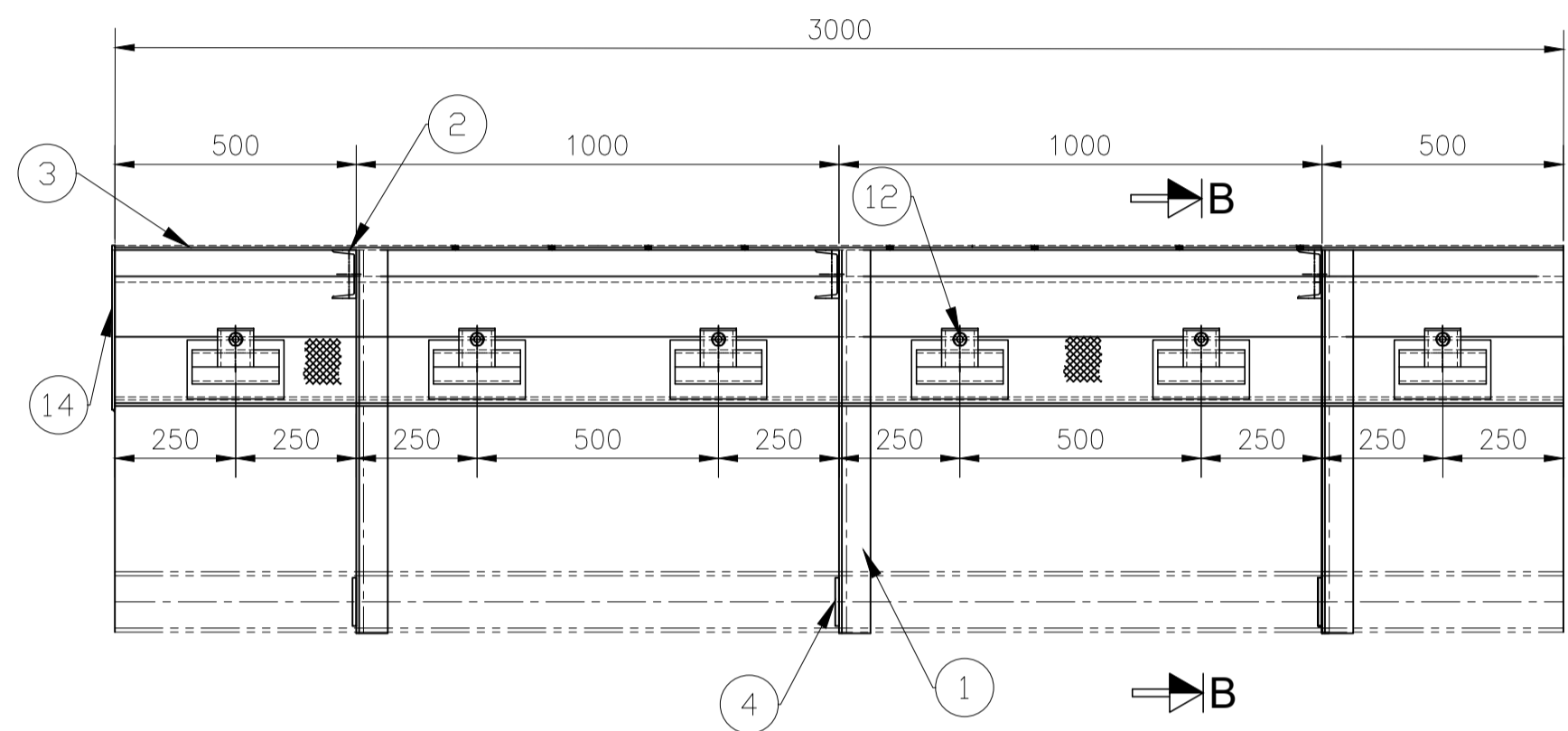

ELEVATION OF SKIRT BOARD

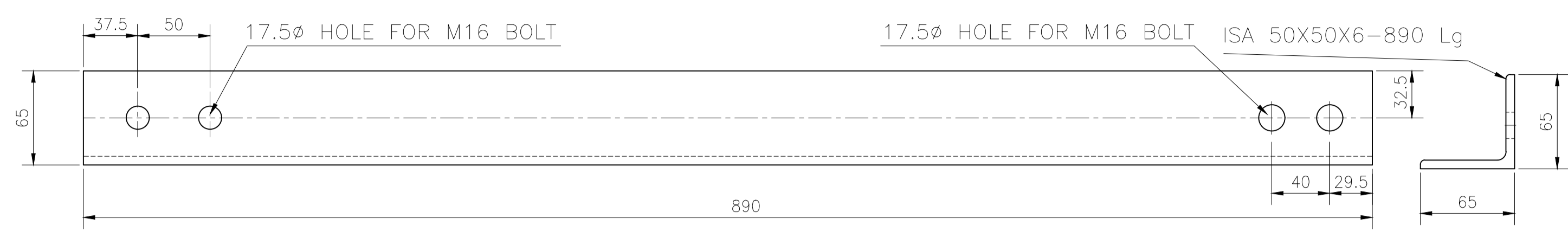

ITEM-1

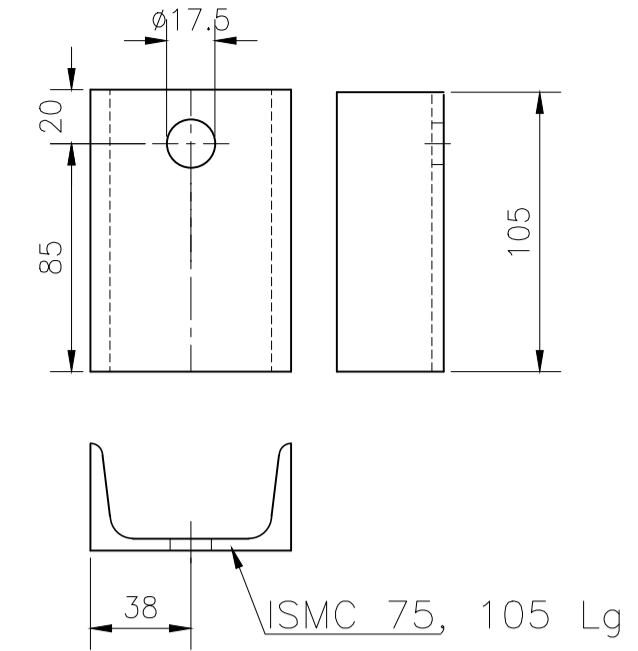

ITEM-7

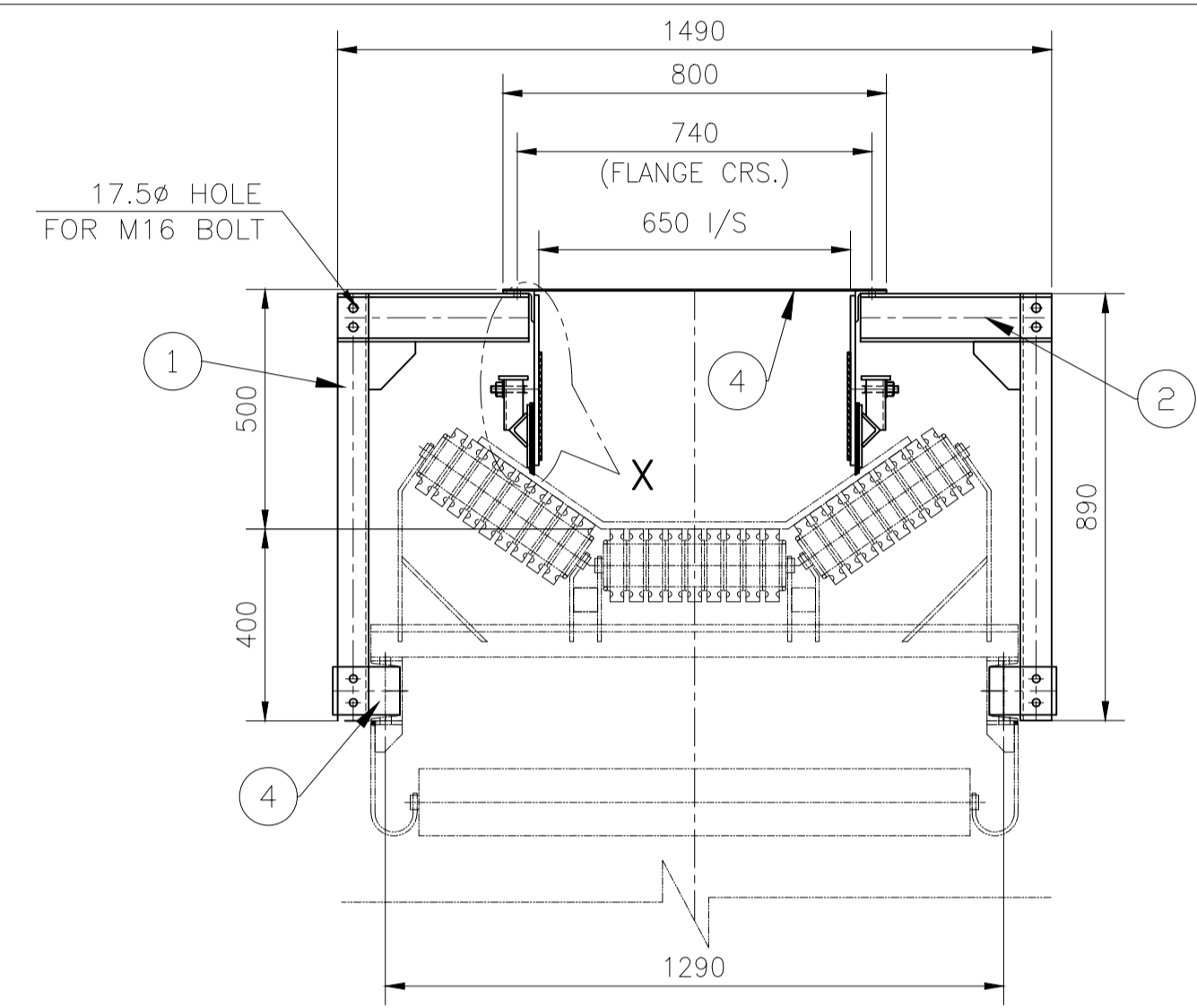

SECTION B-B

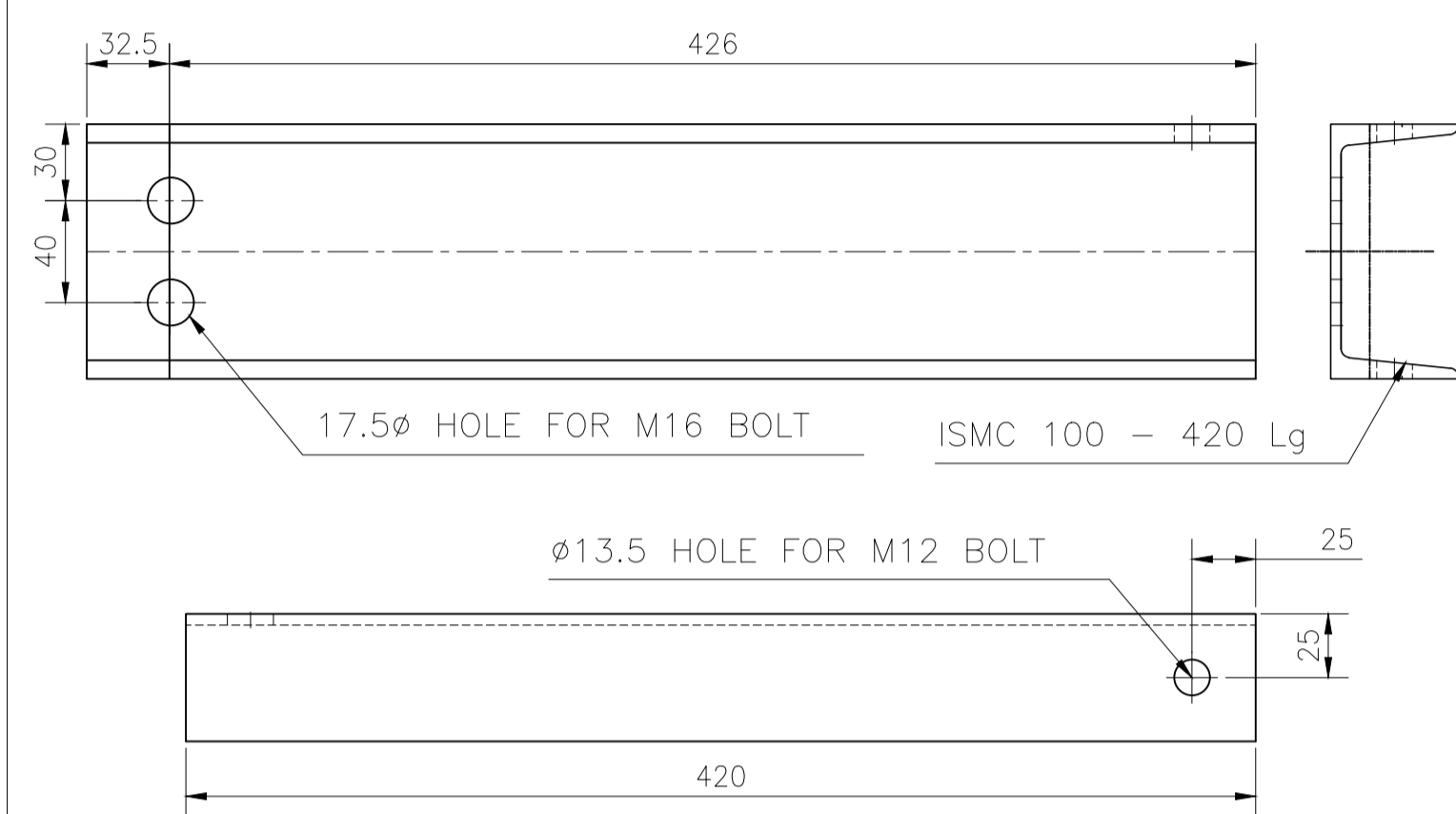

ITEM-2

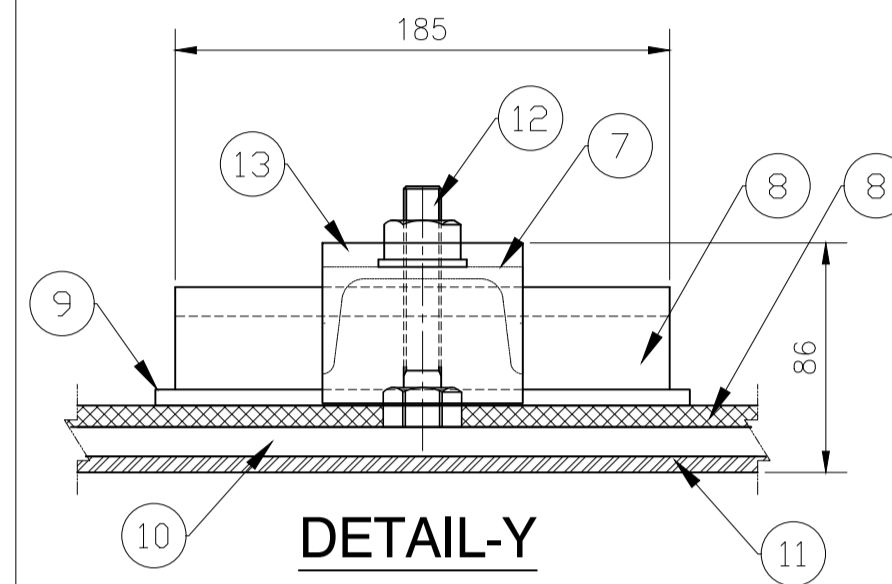

DETAIL-Y

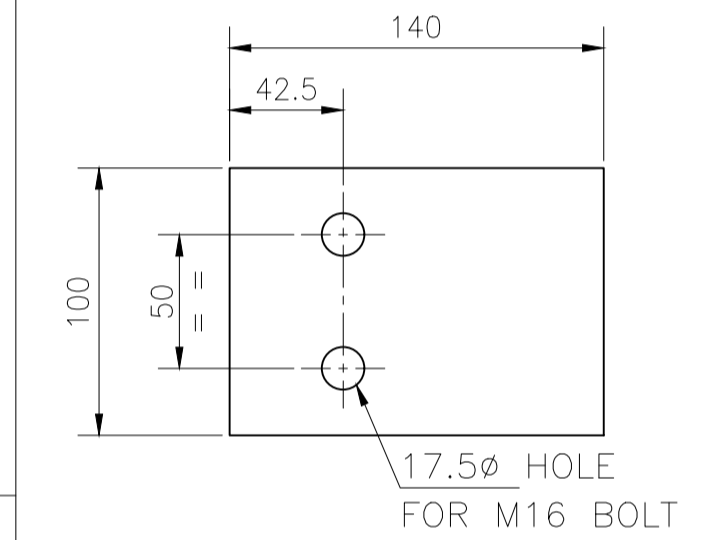

ITEM-4

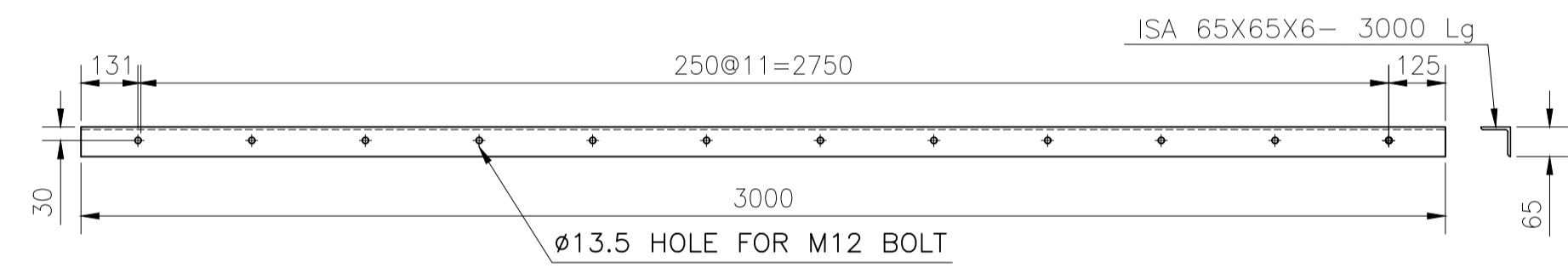

ITEM-6

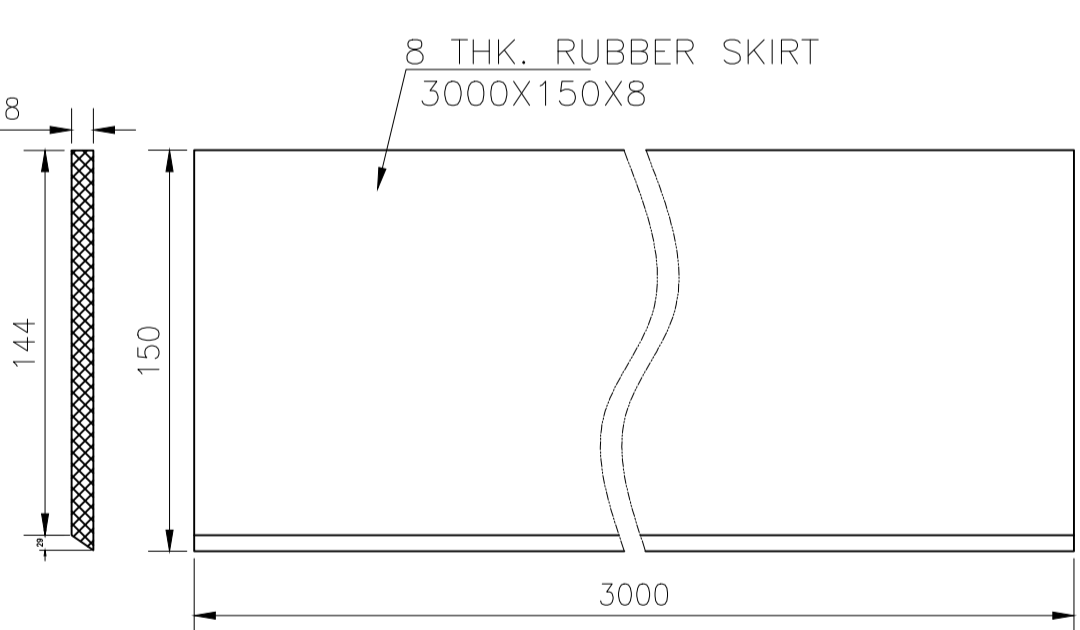

ITEM-5

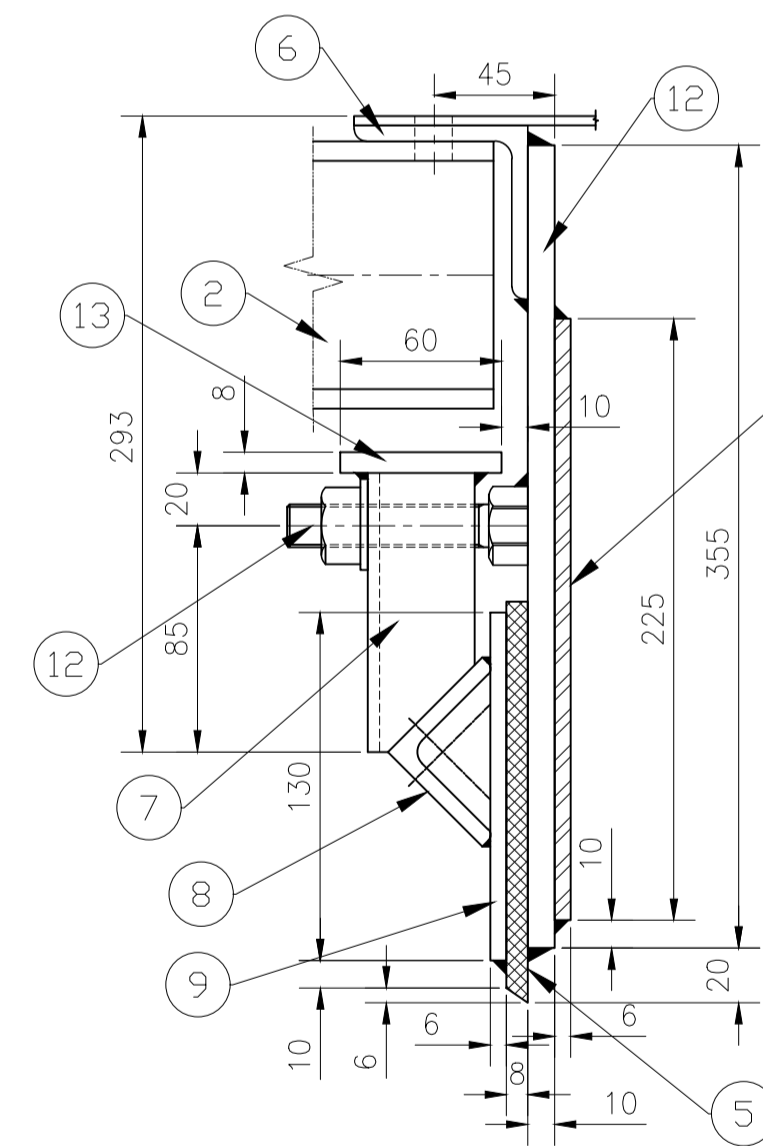

DETAIL-X

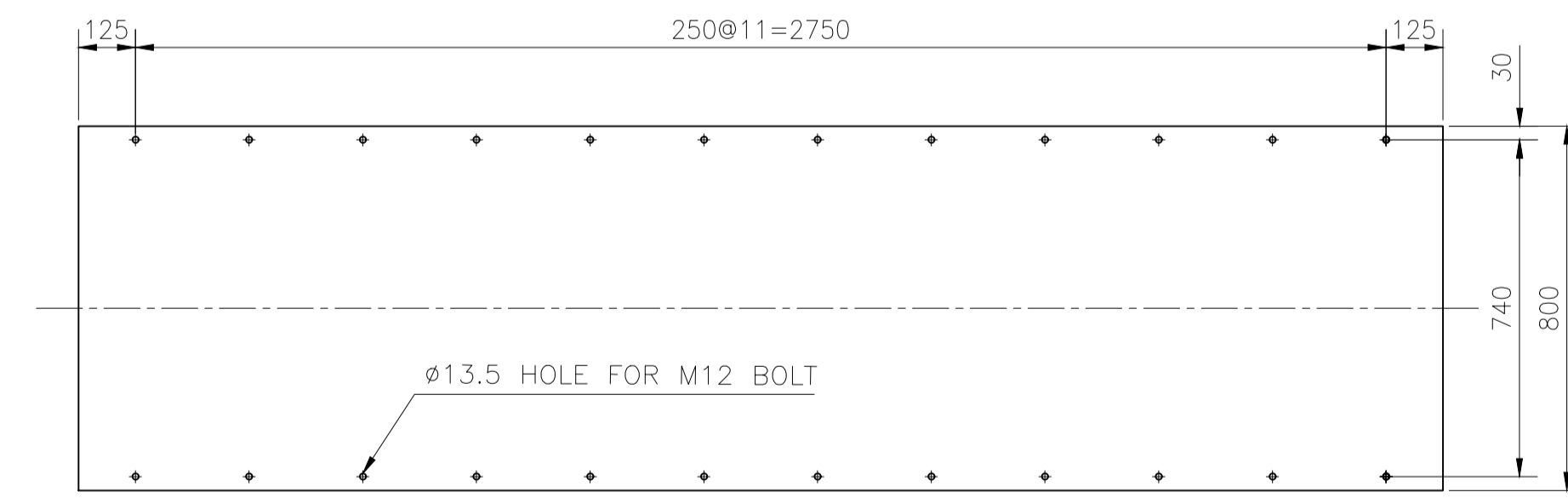

ITEM-3

			TOTAL	455.7	WEIGHT IN (Kg.)
14.	PLATE 6THK , 340 X 670	IS:2062	02	10.7	21.4
13.	PLATE 8THK, 75 X 60	IS:2062	12	0.56	6.72
12.	M16 X 90 LG HEX HD BOLTS, NUTS & WASHER	IS:2062	12	--	--
11.	LINER PLATE 6THK 225 X 3000	UHMW	02	31.8	63.6
10.	PLATE 10THK, 355 X 3000 LG	IS:2062	02	83.60	167.2
9.	PLATE 6THK, 130 X 200LG	IS:2062	12	1.22	14.64
8.	ISA 50X50X6THK , 185 LG	IS:2062	12	0.83	16.6
7.	ISMC75 , 105LG	IS:2062	12	0.75	9
6.	ISA 65X65X6 THK, 3000LG	IS:2062	02	17.4	34.8
5.	RUBBER 8THK, 150X 3000 LG	RUBBER	02	-	-
4.	PLATE 8 THK , 125 X 100	IS:2062	06	0.78	4.68
3.	PLATE 3.15 THK , 930 X 3000 LG	IS:2062	01	69	69
2.	ISMC100, 385 LG	IS:2062	06	4	24
1.	ISA 50X50X6THK , 890LG	IS:2062	06	4	24
PART No.	DESCRIPTION	MATERIAL SPECIFICATION.	QTY.	UNIT	TOTAL WEIGHT IN (Kg.)

BILL OF MATERIAL

- NOTES :-
 1. ALL DIMENSIONS ARE IN MM
 2. ALL WELDS ARE 6MM FILLET CONTINUOUS UNLESS OTHERWISE SPECIFIED
 3. ALL MEMBERS SHOULD BE CUT AFTER FULL SCALE LAYOUT
 4. ALL DRILLED HOLES TO BE MATCH DRILLED WITH THEIR MATING PARTS

SL.NO.	REFERENCE DWG.NO.	REV. No	DATE	DESCRIPTION	BY	APPD BY
2		2				
1		1				

SURFACE FINISH		GEOMETRIC TOLERANCE SYMBOLS		UPPER AND LOWER DEVIATIONS FOR LINEAR DIMENSIONS		
~	50 μm		PARALLEL	∠	ANGULAR	4001 TO 8000 ±3
∇	25 TO 12.5 μm	⊥	PERPENDICULAR	≡	SYMMETRICAL	8001 TO 12000 ±4
∇∇	6.3 TO 1.6 μm	—	STRAIGHT	◎	CONCENTRIC	12001 TO 16000 ±5
∇∇∇	0.8 TO 0.2 μm	▭	FLAT	/	RUNOUT	16001 TO 20000 ±6
∇∇∇∇	0.1 TO 0.025 μm					401 TO 1000 ±0.8
						1001 TO 2000 ±1.2
						2001 TO 4000 ±2

THIS DRAWING IS THE PROPERTY OF PDE, JSWSL AND IS ISSUED FOR THE SPECIFIC PROJECT MENTIONED THEREIN AND NOT TO BE COPIED/USED FOR ANY OTHER PROJECTS.

NAME	SIGNATURE	DATE
CHANUD		24.01.19
CHANDU		24.01.19
CHANDU		25.01.19
UDUPA		25.01.19

PROJECTION THIRD ANGLE

SHEET : 1 OF 1
SCALE : NTS

DEPARTMENT :- SP#4

TITLE :- FAB. DRAWING OF SKIRT BOARD FOR 1000BW CONVEYOR

ISSUED FOR :- APPROVAL / MANUFACTURING / INFORMATION

DRG.No.JSW/PDE/A2/02/22/01/028